

**Description**

The digital power measuring transducer AD-LU 610 GT measures all quantities of the three-phase network (current, voltage, energy, harmonics, phase angle, active power, reactive power, apparent power etc.) and converts these measuring values onto two freely scalable analogue outputs (20 mA / 10 V). With the integral relay, the switching of limiting values or the output of energy pulses is possible. For output of more frequent energy pulses, the AD-LU 610 GT is alternatively also available with transistor output. The unit is therefore optimal suitable for integration in energy management systems. 3- or 4-wire systems can be measured. 4-wire networks can be loaded balanced or unbalanced, whereby 3-wire networks can only be measured balanced. The AD-LU 610 GT is supplied via its measuring voltage L1. The current measuring is carried out via the bar-type transformer mounted on the front. For measuring of high voltages or high currents, external transformers can be connected in series at any time. The AD-LU 610 GT can be read out and parameterised via the integral RS485-interface with the aid of the available AD-Studio. A 96x96 mm TFT display module can also be connected to this interface. The LEDs at the front signals the operating condition, the RS485-data and the relay-status. The compact type of construction and the high performance ability with simultaneous low energy consumption allows usage in almost any application.

**Application**

Typical usage in plant, machines or energy management systems for balancing and determination of energy distribution.

**Specific characteristics**

- compact design
- current measurement via clamp on current transformers
- supplied via its measuring voltage L1
- current and voltage output
- relay or transistor output
- monitoring all variables of the three-phase network
- parameterization via AD-Studio
- RS485 interface
- TFT-Display AD-MM 400 connectable

**Business data****Order number**

Relay output	AD-LU 610 GT
Transistor output	AD-LU 610 GTO

**Accessory (optional)**

VarioPass3	USB-inerface adapter
AD-Studio	configuration software
AD-MM 400	TFT-Display



**Technical specifications****Current-inputs (I1...I3)**

Measuring ranges	0 ... 1 A AC; 0 ... 5 A AC; 0 ... 20 A AC
Max. conductor diameter	4,8 mm
Max. measurable harmonic	40

**Voltage-inputs (L1...L3)**

Measuring range	80 ... 253 V AC
Input resistance	> 900 kOhm

**Output current**

Output range	0/4 ... 20 mA
Max. load	400 Ohm
Resolution	11 Bit
Residual ripple	25 µAss

**Output voltage**

Output range	0/2 ... 10 V
Min. load	10 kOhm
Resolution	11 Bit
Residual ripple	30 mVss

**Relay output**

Maximum switching load AC	250 V, 2 A
Maximum switching load DC	50 V, 2 A
Contact construction	potential-free changeover
Switching operations mechanical	10000000
At 230V/2A AC, cos(phi)=1	600000
At 230V/2A AC, cos(phi)=0,4	200000
At 24V/2A DC	200000
Pulse length min ... max	500 ms ... 10000 ms

**Alternative: transistor output**

Maximum switching load DC	30 V, 50 mA
Pulse length min ... max	50 ms ... 10000 ms

**Supply**

Voltage range AC	80 ... 253 V AC, 50/60 Hz (see voltage-inputs)
Nominal voltage AC	230 V AC
Power consumption	max. 4,7 VA

**RS485-Bus**

Software protocol	Modbus-RTU
Data format	19200, e, 8, 1
Address switch	0...9 (0: service position)
Bus termination	120 ohms both sides at the end
Max. length of bus	500 m (no stubs)
Cable	verdrillt und geschirmt

**Transfer behavior - in reference to the current value**

Basic accuracy	< 0,5 % (class 0.5)
Temperature influence	80 ppm/K
Response time	< 0,5 s

**Housing**

Dimensions (WxHxD)	71x90x70 mm
Type of protection	IP 20
Connection method	screw clamp
Terminals, wire cross section	2,5 mm <sup>2</sup> flex wire / 4 mm <sup>2</sup> one wire
Bolting torque terminals	0,6 Nm
Skinning length	6 mm
Weight	~ 170 g
Manner of fastening	35 mm DIN rail 35mm

**Environmental conditions**

Ambient temperature	0 ... 50 °C
Storage and transport	-10 ... 70 °C (no condensation)

**EMC**

Product family standard	EN 61326 <sup>1)</sup>
Emitted interference	EN 55011, CISPR11 Cl. B

**Electrical safety requirements**

Product family standard	EN 61010-1
Overvoltage category	II
Pollution degree	2
Safety measurement	EN 61010-2-030
Measurement category	CAT III

**Galvanic isolation, test voltages**

Power supply to analog outputs	4 kV, 50 Hz (1 min.)
Power supply to relay	4 kV, 50 Hz (1 min.)
Relay to analog outputs	4 kV, 50 Hz (1 min.)

**Protection circuits**

Input	electrical surge protection
Power supply	protection against over-temperature, over-voltage and over-current
Analog outputs	electrical surge protection

<sup>1)</sup> During checking, slight signal deviations are possible.

### Block and wiring diagram

### Dimensions

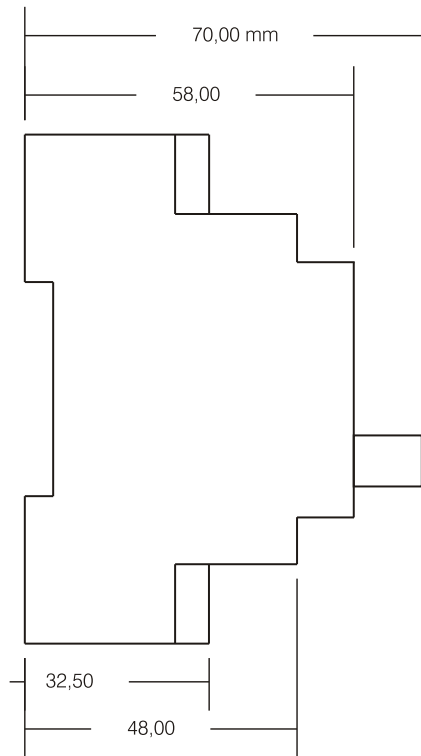
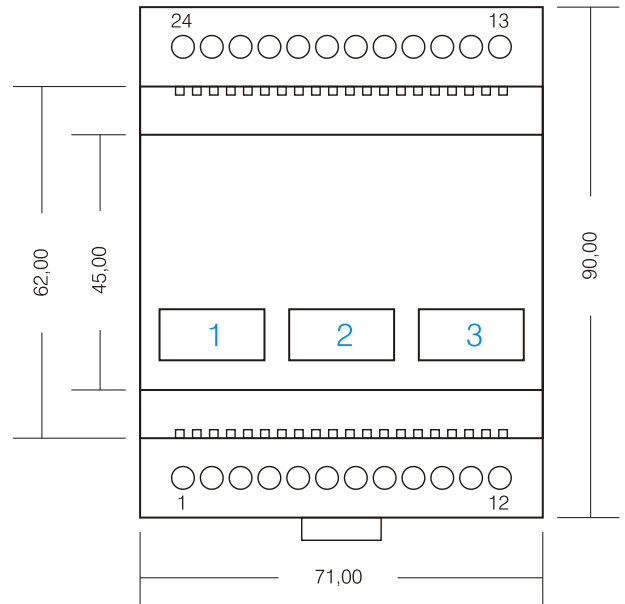
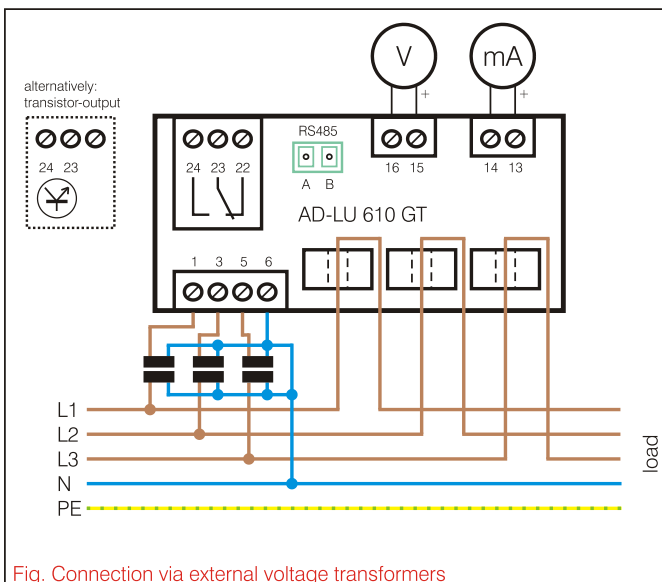
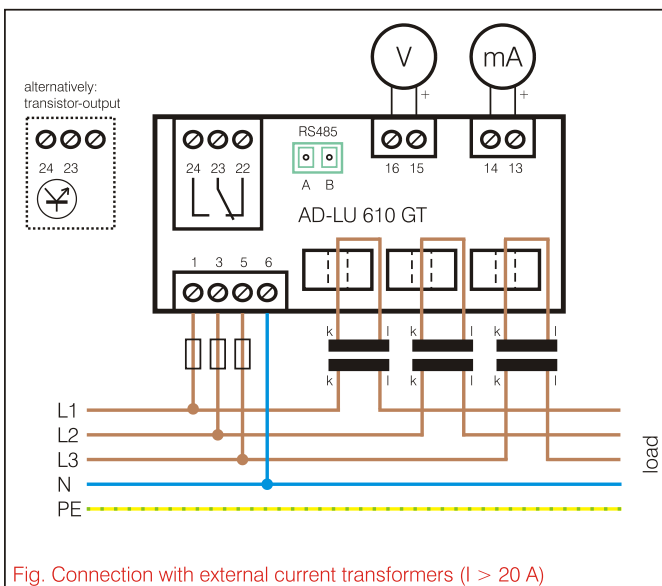
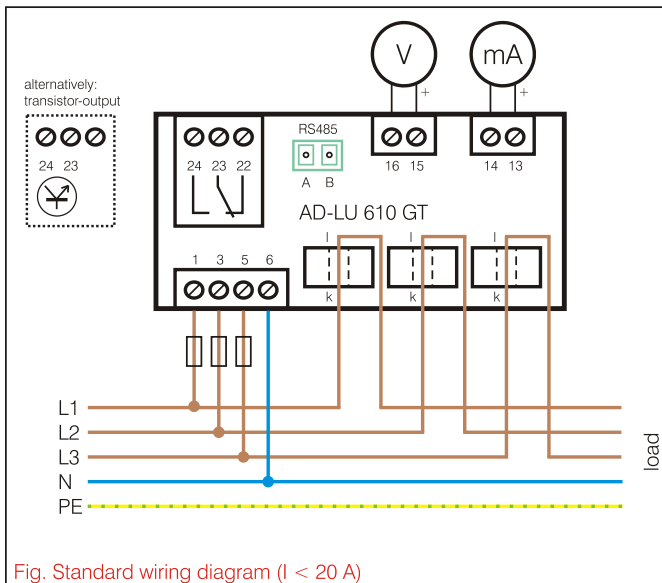

**Hinweis:**  
Für die Messung symmetrischer Lasten kann das Gerät so umparametriert werden, dass nur ein Stromwandler für die Messung notwendig ist. In diesem Fall bitte die Strommessung mit Stromwandler 1 auf Phase L1 durchführen.

### Modbus Communication

The AD-LU 610 GT has a RS485 bus interface on which the Modbus RTU protocol is used. About this bus interface all measured data of the unit can be read out.

The default standard data format is 19200,e,8,1. Adaptation to a different data format is always possible.

<b>data rate:</b> 19200 baud (bits/s)	<b>parity:</b> even	<b>data bit:</b> 8	<b>stop bit:</b> 1
---------------------------------------	---------------------	--------------------	--------------------

The bus address is set at the front mounted rotary switches. The address 0 is prohibited for bus application. However, on this zero position the device always uses the standard data format (19200, e, 8,1). The position 0 therefore represents a service position, can be used for example at incorrect parameterization.

The AD-LU 610 GT supports two Modbus functions. These are the functions **"Read Holding Registers" (0x03)** and **"Write Multiple Registers" (0x10)**. The function **"Read Holding Registers"** data can be read from the device and data is written with **"Write Multiple Registers"**. The individual register width is 16 bits.

Please refer to the Modbus specification for a detailed description of the Modbus communication. This is freely available online, but can also be obtained from the Adamczewski homepage.

The following Modbus data are accessible via the RS485 bus:

start address	no. of registers	name	unit	data type	read	write
---------------	------------------	------	------	-----------	------	-------

#### Messwerte:

40501	2	SCA_TOTAL_ACTIVE_POWER	kW	7	1	0
40503	2	SCA_PHASE_A_ACTIVE_POWER	kW	7	1	0
40505	2	SCA_PHASE_B_ACTIVE_POWER	kW	7	1	0
40507	2	SCA_PHASE_C_ACTIVE_POWER	kW	7	1	0
40509	2	SCA_TOTAL_REACTIVE_POWER	kvar	7	1	0
40511	2	SCA_PHASE_A_REACTIVE_POWER	kvar	7	1	0
40513	2	SCA_PHASE_B_REACTIVE_POWER	kvar	7	1	0
40515	2	SCA_PHASE_C_REACTIVE_POWER	kvar	7	1	0
40517	2	SCA_TOTAL_APPARENT_POWER	kVA	7	1	0
40519	2	SCA_PHASE_A_APPARENT_POWER	kVA	7	1	0
40521	2	SCA_PHASE_B_APPARENT_POWER	kVA	7	1	0
40523	2	SCA_PHASE_C_APPARENT_POWER	kVA	7	1	0
40525	2	SCA_TOTAL_POWER_FACTOR		7	1	0
40527	2	SCA_PHASE_A_POWER_FACTOR		7	1	0
40529	2	SCA_PHASE_B_POWER_FACTOR		7	1	0
40531	2	SCA_PHASE_C_POWER_FACTOR		7	1	0
40533	2	SCA_TOTAL_ACTIVE_FUNDAMENTAL_POWER	kW	7	1	0
40535	2	SCA_PHASE_A_ACTIVE_FUNDAMENTAL_POWER	kW	7	1	0
40537	2	SCA_PHASE_B_ACTIVE_FUNDAMENTAL_POWER	kW	7	1	0
40539	2	SCA_PHASE_C_ACTIVE_FUNDAMENTAL_POWER	kW	7	1	0
40541	2	SCA_TOTAL_ACTIVE_HARMONIC_POWER	kW	7	1	0
40543	2	SCA_PHASE_A_ACTIVE_HARMONIC_POWER	kW	7	1	0
40545	2	SCA_PHASE_B_ACTIVE_HARMONIC_POWER	kW	7	1	0
40547	2	SCA_PHASE_C_ACTIVE_HARMONIC_POWER	kW	7	1	0
40549	2	SCA_PHASE_A_VOLTAGE_RMS	V	7	1	0
40551	2	SCA_PHASE_B_VOLTAGE_RMS	V	7	1	0
40553	2	SCA_PHASE_C_VOLTAGE_RMS	V	7	1	0
40555	2	SCA_N_LINE_CALCULATED_CURRENT_RMS	A	7	1	0
40557	2	SCA_PHASE_A_CURRENT_RMS	A	7	1	0
40559	2	SCA_PHASE_B_CURRENT_RMS	A	7	1	0
40561	2	SCA_PHASE_C_CURRENT_RMS	A	7	1	0
40563	2	SCA_CHANNEL_A_VOLTAGE_PEAK	V	7	1	0
40565	2	SCA_CHANNEL_B_VOLTAGE_PEAK	V	7	1	0
40567	2	SCA_CHANNEL_C_VOLTAGE_PEAK	V	7	1	0
40569	2	SCA_CHANNEL_A_CURRENT_PEAK	A	7	1	0
40571	2	SCA_CHANNEL_B_CURRENT_PEAK	A	7	1	0
40573	2	SCA_CHANNEL_C_CURRENT_PEAK	A	7	1	0
40575	2	SCA_FREQUENCY	Hz	7	1	0
40577	2	SCA_PHASE_A_MEAN_PHASE_ANGLE	°	7	1	0
40579	2	SCA_PHASE_B_MEAN_PHASE_ANGLE	°	7	1	0
40581	2	SCA_PHASE_C_MEAN_PHASE_ANGLE	°	7	1	0
40583	2	SCA_MEASURED_TEMPERATURE	°C	7	1	0
40585	2	SCA_PHASE_A_VOLTAGE_PHASE_ANGLE	°	7	1	0
40587	2	SCA_PHASE_B_VOLTAGE_PHASE_ANGLE	°	7	1	0
40589	2	SCA_PHASE_C_VOLTAGE_PHASE_ANGLE	°	7	1	0
40591	2	SCA_VOLATGE L1 L2	V	7	1	0
40593	2	SCA_VOLATGE L2 L3	V	7	1	0
40595	2	SCA_VOLATGE L3 L1	V	7	1	0

## Modbus-Data

start address	register count	name	unit	type	read	write
---------------	----------------	------	------	------	------	-------

## List-parameters:

41001	1	LIST_LOADTYPE		3	1	1
41003	1	LIST_BAUDRATE		3	1	1
41004	1	LIST_STOPBIT		3	1	1
41005	1	LIST_PARITY		3	1	1
41006	1	LIST_MEASSUREMENT_ASSIGNMENT_IOUT		3	1	1
41007	1	LIST_MEASSUREMENT_ASSIGNMENT_UOUT		3	1	1
41008	1	LIST_RELAY_FUNCTION		3	1	1
41009	1	LIST_MEASSUREMENT_ASSIGNMENT_REL_S0		3	1	1
41010	1	LIST_MEASSUREMENT_ASSIGNMENT_REL_LIMIT		3	1	1
41011	1	LIST_RELAIS_WORKING_TYPE		3	1	1

## Data-parameters:

41501	2	DATA_FILTER	s	7	1	1
41503	2	DATA_PRIMARY_CURRENT	A	7	1	1
41505	2	DATA_SECUNARY_CURRENT	A	7	1	1
41507	2	DATA_PRIMARY_VOLTAGE	V	7	1	1
41509	2	DATA_SECUNARY_VOLTAGE	V	7	1	1
41511	2	DATA_REL_SWITCH_ON_TIME	V	7	1	1
41513	2	DATA_REL_SWITCH_OFF_TIME	V	7	1	1
41515	2	DATA_REL_S0_PULSE_VALUE	V	7	1	1
41517	2	DATA_REL_PULSE LENGHT	V	7	1	1

## Counter:

43503	2	COUNTER_KWH_TOTAL_CONSUPTION	kWh	5	1	1
43505	2	COUNTER_KWH_TOTAL_INFEED	kWh	5	1	1
43507	2	COUNTER_KVARH_TOTAL_INDUCTIVE	kVarh	5	1	1
43509	2	COUNTER_KVARH_TOTAL_CAPACITIVE	kVarh	5	1	1
43511	2	COUNTER_KVAH_TOTAL	kVAh	5	1	1

## Legend of the Datatypes:

U08: 1	S08: 2	U16: 3	S16: 4	U32: 5	S32: 6	float: 7
--------	--------	--------	--------	--------	--------	----------

## Encoding of the list-parameters (list index:value):

load type	0:unequal	1:equal								
baudrate	0:2400	1:4800	2:9600	3:14k4	4:19k2	5:28k8	6:38k4	7:57k6	8:76k8	9:115k2
stopbit	0:1	1:2								
parity	0:even	1:odd	2:none							
meass. assignm. Iout	Index corresponds to measured value list: starting from 0									
meass. assignm. Uout	Index corresponds to measured value list: starting from 0									
relay function	0:limit.	1:S0	2>window	3:energy						
				-direction						
meass. assign. Rel S0	0:Ptot C.	1:Ptot I.	2:Qtot L	3:Qtot C	4:Stot					
meass. assign. Rel limit	Index corresponds to measured value list: starting from 0									
working type Rel	0:work	1:rest								